

## PTLD I

### **TREATMENT OF PATIENTS WITH POST-TRANSPLANT LYMPHOPROLIFERATIVE DISORDER (PTLD) WITH A SEQUENTIAL TREATMENT CONSISTING OF ANTI-CD20 ANTIBODY RITUXIMAB AND CHOP + GCSF CHEMOTHERAPY (including first amendment)**

#### **Heads Study Group**

PD Dr. I. Anagnostopoulos, Prof. Dr. H. Stein. Institute for Pathology, Benjamin Franklin University Clinic, Berlin, Germany.

Prof. Dr. B. Borisch, D. M. Tinguely. Pathology, Hopitaux Universitaires de Geneve, Switzerland.

Prof. Dr. U. Jaeger, Dept.of Medicine I, Div. of Hematology and Hemostaseology, AKH, Universität Wien, Österreich.

Pr. V. LeBlond, Dr. S. Choquet. Haematology, Hôpital Pitié-Salpêtrière, Paris, France.

Pr. N. Milpied. Haematology, CHU Hôtel-Dieu, Nantes, France.

Dr. Martine Raphael, Dr. H. Poirel, Pathology, Hôpital Avicenne, Bobigny cedex, France.

Prof. Dr. H. Riess, Dr. R. Trappe, Prof. Dr. B. Dörken. Haematology and Oncology, Universitätsklinikum Charité, Humboldt Universität Berlin, Germany.

Dr. T. Ekman, Dr. M. Sender. Haematology and Oncology, Sahlgrens Hospital, Gothenburg, Schweden.

Dr. A. F. de Sevilla, Dr. E. Gonzalez-Barca, Haematology and Oncology, L'Hospitalet de Llobregat, Barcelona, Spain.

#### **Co-ordination**

Dr. med. R. Trappe, Department of Internal Medicine, Haematology and Oncology, Universitätsklinikum Charité-Campus Virchow-Klinikum, Humboldt Universität Berlin, Augustenburger Platz 1, Mittelallee 11, 13353 Berlin, Tel.: 030-450553510, Fax: 030-450553901, e-mail: [ralf.trappe@charite.de](mailto:ralf.trappe@charite.de)

## ***Table of contents***

### **1. Background**

- 1.1 Disease background
- 1.2 Drug background
  - 1.2.1 Preclinical data of rituximab
    - 1.2.1.1 Specificity and mode of action
    - 1.2.1.2 Preclinical data about toxicity and pharmacology
  - 1.2.2 Clinical data of rituximab
- 1.3 Clinical data of CHOP chemotherapy
- 1.4 Study rationale

### **2. Study Objectives**

- 2.1 Primary objectives
- 2.2 Secondary objectives

### **3. Study Duration and Early Termination**

### **4. Participating Centers**

### **5. Selection Criteria**

- 5.1 Total number of patients
- 5.2 Study population
- 5.3 Inclusion criteria
- 5.4 Exclusion criteria
- 5.5 Admission to study

### **6. Disease Evaluation (Efficacy Criteria)**

- 6.1 Diagnostics
  - 6.1.1 Diagnostics prior to onset of therapy
  - 6.1.2 Diagnostics during therapy and after end of therapy
    - 6.1.2.1 Measurement of EBV viral load in peripheral blood
  - 6.1.3 Criteria for evaluation
- 6.2 Assessment of efficacy
  - 6.2.1 Primary efficacy parameter
  - 6.2.2 Secondary efficacy parameter
- 6.3 Assessment of safety

## **7. Study Treatment**

- 7.1 Treatment plan
  - 7.1.1 Concomitant medications
  - 7.1.2 Dosage and preparation of rituximab
    - 7.1.2.1 Preparation of rituximab
    - 7.1.1.2 Application of rituximab
    - 7.1.1.3 How to handle side effects during infusion
  - 7.2 Dosage and rationale for application of CHOP chemotherapy
    - 7.2.1 Toxicity of CHOP chemotherapy
    - 7.2.2 Dose adaptations due to organ function

## **8. Discontinuation of Study**

## **9. Provisional Analysis of the Study**

## **10. Informing of Patients and Ethics**

## **11. References**

## **12. Appendices**

- A. WHO toxicity-scale
- B. Criteria of remission and criteria of activity and toxicity (WHO guidelines)
- C. ECOG / Karnofsky-Score
- D. September 1989 – World Medical Association Declaration of Helsinki
- E. Patients' information and agreement sheet
- F. Pathology form, which is to be sent with the resected tissue
- G. Laboratory form for measurement of EBV viral load

**Protocol title:**  
***Treatment of Patients with Post-transplant Lymphoproliferative Disorders (PTLD) with a sequential treatment consisting of Anti-CD20 Antibody (Rituximab) and CHOP + GCSF chemotherapy***

**Synopsis of Protocol**

<b>Project Phase:</b>	II
<b>Indication:</b>	Untreated CD20+ lymphoproliferative disorders following transplantation of organs.
<b>Objectives:</b>	To determine the safety and the efficacy of a sequential therapy consisting of rituximab antibody followed by CHOP chemotherapy in patients with CD20+ Post-transplant lymphoproliferative disorder (PTLD) after organ transplantation.
<b>Study design:</b>	Open label, single arm study.
<b>Planned sample size:</b>	100 patients
<b>Number of centers:</b>	30
<b>Patient selection criteria:</b>	Female or male patients with confirmed lymphoproliferative disorders after organ transplantation (e.g. heart, lung, liver, bone marrow and kidney etc.) with stage I-IV.
<b>Study medication:</b>	Treatment with the anti-CD20 monoclonal antibody rituximab. The antibody will be given at a dosage of 375 mg/m <sup>2</sup> i.v. infusion, once a week for 4 infusions. After an interval of 4 weeks 4 cycles of CHOP 21 chemotherapy will be given
<b>Main parameters of efficacy:</b>	Objective response rate.
<b>Main parameters of safety:</b>	Adverse events.
<b>Statistical analysis:</b>	Descriptive statistics.
<b>Duration of the study:</b>	36 months.

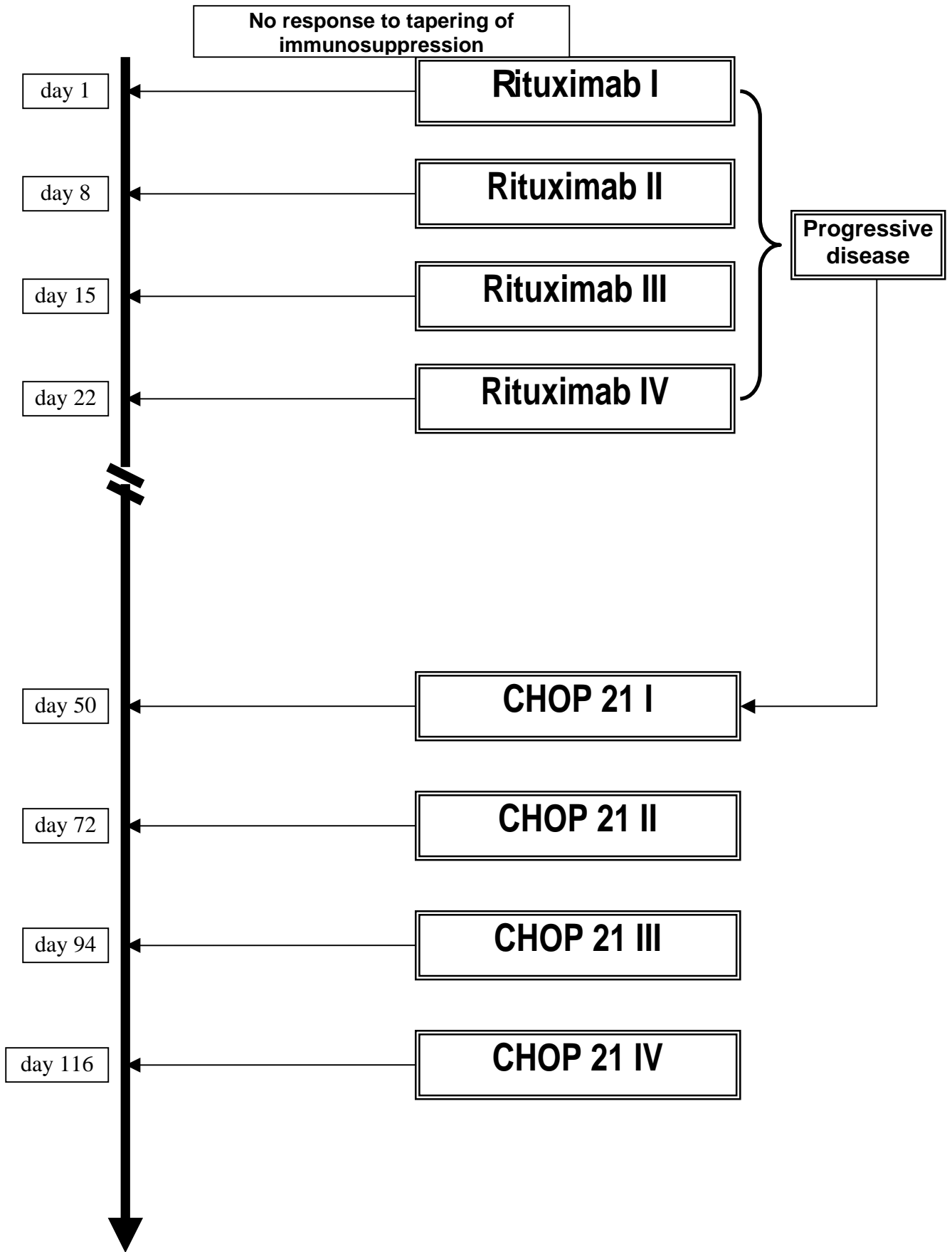

## 1. Background

### 1.1. *Lymphoproliferative disorders after solid organ transplantation*

**Organ transplantation and malignancies:** In the past 20 years solid organ transplantations have become established as part of the daily clinical routine. A great amount of success achieved in transplantation medicine is due to pharmacological progress in the development of immunosuppressive drugs. By the introduction of cyclosporine A in 1979, the frequency and degree of rejection of transplanted organs was diminished to a remarkable extent. The number of postoperative complications, such as infections and mortality, after organ transplantations decreased significantly. The methods of heart, lung, heart-lung, liver, pancreas, small intestine and kidney transplantations have been established in a still growing number of institutions. One-year-survival-rates of patients having undergone heart, lung, or liver transplantation are now up to 80–90%, 60–70% or 80–90%, respectively (1,2).

This progress in immunosuppression, however, was accompanied by a higher incidence of malignant diseases. In 1968 Penn reported on the high incidence of lymphomas in patients having undergone kidney transplantation (3). Since this publication it has been confirmed that in patients with solid organ transplantation and concomitant immunosuppression a higher incidence of certain malignant diseases has to be expected when compared with the healthy population. Among these malignant diseases are the following: Post-transplantation lymphoproliferative disorders (PTLD), squamous cell carcinomas of the lip and skin, Kaposi's sarcoma, carcinoma of the vulva, hypernephroma and hepatobiliary tumors. PTLD affect 1–10% of patients having undergone solid organ transplantation.

**Immunodeficiency and malignancies:** First reports about the connection between primary immunodeficiency and the development of malignant disease, especially neoplasias of the lymphatic system, were published in the late fifties (6,7). Incidences of neoplasia in patients with Wiskott-Aldrich syndrome were calculated to be 7.6% (8), 1.4–7% in patients with Common Variable Immunodeficiency (CVID) (9) and 10% in patients with Ataxia-Teleangiectasia (10). In addition to these primary immunodeficiencies, in which neoplasia may occur, lymphoproliferative disorders that range from seemingly reactive lymphatic reactions to clearly malignant lymphoma have also been observed secondarily in patients with HIV infection (11), in patients with rheumatoid arthritis, Sjögren- syndrome and in patients receiving immunosuppressive drugs, like organ transplant recipients (95).

**Epstein-Barr virus and malignancies:** The Epstein-Barr virus (EBV), the viral pathogen that causes infectious mononucleosis, is associated with several malignant diseases. Having first been identified in a cell culture of endemic Burkitt lymphoma (12), it has also been found in classic Hodgkin's disease (14), in several forms of non-Hodgkin's lymphoma, especially in the lymphoma of a T-cell phenotype, in the undifferentiated form of nasopharyngeal carcinoma (13) and also in some other carcinomas (16). EBV is believed to be the main causative factor in the development of PTLD. The viral genome can be detected in 70-90% of cases of PTLD. Whether EBV negative PTLD occurs primarily or the virus is lost during development of PTLD, is currently not completely understood.

**Incidence:** Of all cases developing malignant disease after organ transplantation 15–25% are due to PTLD (17,18). The incidence of PTLD varies, depending on the

intensity of immunosuppression and the transplanted organ. The incidence of PTLD in liver transplantation has been calculated to be 1.4–2% (8,9,15), 1.8–2.5% in heart transplantation (20,21,22) and 4.5–9.4% in lung transplantation (2,20,22).

In bone marrow recipients, the cumulative incidence of PTLD is 1% at 10 years (114).

In the 18th annual report of the International society for heart and lung transplantation among 30882 heart transplant recipients 3.5% developed a malignancy in the first year after heart transplantation (HTX) and 29% of them had a PTLD. After 5 years 8.8% of patients had experienced a malignancy and 12.5% of these were PTLD. Furthermore in 3339 lung transplant recipients 4.4% experienced a malignancy in the first year after transplantation and 53.1% of these were PTLD. After 5 years 5.8% had malignant disease and 16.7% were PTLD.

**Histology:** Due to their clinical development and their histological characteristics, PTLD were initially considered to be non-Hodgkin's lymphomas (NHL) (3). With increase in number of graft recipients and associated higher incidence of PTLD, the realization of the disease's separate entity grew. PTLD represents a heterogeneous group of lymphoproliferative disorders induced in most cases by EBV. PTLD originates from polyclonal expansions of EBV infected cells, which then develop into monoclonal B-cell lymphomas. Several authors have tried to divide these lymphoproliferations into different morphological categories. Frizzera et al. (20) suggested stringent morphological criteria in order to differentiate between benign (so called polymorphous hyperplasia) and malignant (so called polymorphous B-cell lymphoma) PTLD. These morphological criteria, however, have not been correlated to molecular, biological or clinical data so far. Nalesnik et al. (21) recommended the division of PTLD into two main groups, namely polymorphous and monomorphous PTLD. Neither morphology nor clonality of these lymphoproliferations were reliable parameters for the estimation of clinical outcome. It was mainly Knowles et al. (25) who compared morphology and molecular biology of lymphoproliferations with clinical features. The classification of PTLD is based on the current suggestion of the WHO for the classification of malignant lymphomas and lymphoproliferative disorders. (96)

#### Early lesions

- Reactive plasmacytic hyperplasia
- Infectious mononucleosis-like

#### Polymorphic PTLD (P-PTLD)

#### Monomorphic PTLD (M-PTLD)

- B-cell neoplasms :
  - Diffuse large B-cell lymphoma
  - Burkitt/Burkitt-like lymphoma
  - Plasma cell lymphoma
  - Plasmacytoma-like lesions

- T-cell neoplasms :

Hodgkin lymphoma and Hodgkin lymphoma-like PTLD

**Clinical presentation:** Clinical appearance of PTLD varies to a great extent.

Two groups that differed in their clinical appearances were first identified in recipients of kidney transplants (28).

One group consisted of young patients (average age: 21 years) who developed mononucleosis-like symptoms shortly after transplantation or shortly after an episode of rejection of the graft (after an average of 9 months). About 50% of the patients suffered from a severe and rapid decline, which resulted in death.

The second group consisted of older patients (average age: 47 years), who developed the disease after a longer post-transplantation interval (an average of 5.3 years). Clinically, these patients with PTLD often presented with a localized extranodal tumor mass. Clinical progression of the disease was often delayed, but, nevertheless, fatal in most cases.

It has often been tried to establish a relationship between transplantation of heart, liver or lung and the respective presentation, clinical development and prognosis of PTLD (2,27,29). Study results are contradictory, which may be due to the small number of cases, differing regimens of immunosuppressive drugs and to the heterogeneity of the disease.

**EBV and PTLD:** Initially the role of EBV in the development of PTLD was unclear. Clinically and serologically, primary and secondary infection with EBV (30,31) and greater nasopharyngeal excretion of the virus in organ recipients (32,33,34) attracted growing attention. Additional clues in the investigation of EBV's role in the development of PTLD were provided by studies on EBV-DNA hybridization (35) and immunohistochemical finding of Epstein-Barr nuclear antigen (EBNA) in PTLD (36). In the ensuing studies, these findings were confirmed several times. By the use of the DNA slot blot (37), the Southern blot (8,39,40,41) or *in situ* hybridization (42,43), the genetic material of EBV was found in some 90% of the cases with PTLD. Furthermore, the EBV-encoding latency phase proteins, LMP 1 and EBNA-2, were found immunohistologically by the use of monoclonal antibodies. These proteins have oncogenic potential, which possibly leads to the transactivation of viral or cellular genes (46,47,48). EBV probably is the most decisive and important factor in the development of lymphoproliferative disorders in organ recipients. Another potentially oncogenic factor is the chronic stimulation of the recipient's immune system by the graft's antigens (21).

Proliferation of EBV-infected B-cells in a healthy individual is normally hampered by complex immunological mechanisms. Surely the most important mechanism is the reaction against EBNA-2 and LMP-1, mediated by CD4+ and CD8+ T-lymphocytes (50,51). Further specific and unspecific immune reactions, which can be found *in vitro*, such as specific humoral reactions (52), NK-cell activity (53), monocytic function changes and release of  $\gamma$ -interferon, also undoubtedly play an important role in infected patients (54).

**Genetic features:** Clonal immunoglobulin (Ig) (or T-cell receptor) gene rearrangement is detected in virtually all monomorphic PTLD, and in most of polymorphic cases. But polyclonal Ig gene pattern is usually observed in early lesions (110).

Only few studies of gene alterations known to be involved in lymphomas (ie oncogenes : c-MYC, BCL1, BCL2, H-, K-, N-, -RAS, or tumor suppressor genes : P53) have been performed : c-MYC, N-RAS and P53 abnormalities were rare and mainly detected in M-PTLD. . The 5' non coding region mutations of BCL6 gene occur in most of the M-PTLD and also in half of the P-PTLD and are associated with an aggressive clinical outcome (111).

Very few cytogenetic analyses are published. A recent CGH (Comparative Genomic Analysis) study performed on 37 PTLD, which will be presented at the annual



meeting of ASH 2002, demonstrates the prognosis value of genomic imbalances in PTLDs (detected in monomorphic-PTLD as well as in polymorphic-PTLD) ( $p < 0.04$ ). Looking at the EBV status, it highlights that chromosomal imbalances are significantly more complex ( $\geq 3$  CGH abnormalities) in EBV negative PTLDs than in EBV positive PTLDs ( $p < 0.02$ ) (112).

**Immunosuppressive drugs and PTLD:** Immunosuppressive drugs applied after organ transplantation restrict normal immunological reactions to such a degree (55) that EBV-infected B-lymphocytes may proliferate uncontrollably. In patients who are being treated with azathioprine and prednisolone, EBV-specific cytotoxic T-cell activity is reduced (56) and a loss of NK-cells results in serious limitation in NK-cell activity (57). The murine monoklonal antibody of the immunoglobulin Ig2a isotype called OKT3 also leads to limitation of cytotoxic T-cell-activity against lymphocytes that have been infected with EBV (58). The effects of cyclosporine A and tacrolimus on immunological reactions are more diverse (59). Cyclosporine A and tarolimus modify the activity of T-cells, of B-cell subgroups (60) and antigen-presenting cells (61). The most important pathogenic factor in the development of PTLD under treatment with cyclosporine A or tacrolimus probably lies in the hampering of the antigen-induced activation of the IL-2-gene, which leads to inhibition of the normal T-cell reaction (62,63).

**Pathogenesis:** Several study groups agree that lymphoproliferative disorders after organ transplantation develop gradually. It is commonly believed that immunosuppressive treatment leads to reactivation of latent EBV infection or to a primary infection with EBV. In these patients EBV may act as a permanently active oncogene. With normal control of B-cell proliferation by the immune system missing, EBV-infected and everlasting B-cell-clones (polyclonal populations) proliferate. As these clones have advantages with respect to proliferation, they outgrow, resulting in dominance of a few clones (oligoclonal) or a single EBV-infected B-cell clone. These clones seem to be sensitive to further genetic transformations, e.g. structural transformations of oncogenes and tumor-suppressor genes. Under these circumstances, a fully transformed, monoclonal B-cell population may develop. In order to explain why PTLD develops in some patients, other factors with a negative influence need to be taken into account. Among these are the kind of EBV infection (primary, reactivated or latent), an increased sensitivity to viral infections, such as CMV, HHV-6, HHV-8 (64,65,66), type and degree of immunosuppression, episodes of graft rejection, type and degree of rejection therapy, therapy with OKT3 (57) and type of the transplanted organ.

### **Therapy:**

**Reduction of immunosuppression:** Bone marrow recipients suffer a profound endogenous immunodeficiency during immune reconstitution by the donor graft. Simple withdrawal of immune suppression in such patients does not lead to rapid immune recovery but can rather induce flares of GVHD and further delay in recovery of the T-cell mediated immunity. In contrast it is widely agreed that reduction of immunosuppression is the initial therapy in patients expected to suffer from PTLD after solid organ transplantation (21,68,69). This method, which was first described by Starzl et al. in 1984 (69), leads to a continuous remission of disease without further need of treatment in a few patients. Despite encouraging, retrospective reports (97) it seems to be clear that only a small subset of patients with early lesions or some with polymorphous lymphoproliferations benefit of reduction of

immunosuppression. Nevertheless in all patients with PTLD, except after bone marrow transplantation, the immunosuppression should be reduced.

**Surgery:** Single center reports suggest that a complete surgical tumorexstirpation in patients with localized stage of PTLD can result in long lasting remissions. Results of prospective trials are not available.

**Radiotherapy:** Single center reports suggest that a radiotherapy in patients with localized stage of PTLD can result in long lasting remissions. Results of prospective trials are not available.

**Antiviral therapy:** As EBV is involved in the PTLD pathogenesis, attempts have been made to influence EBV- infection by antiviral drugs acting on viral DNA cycle. The EBV encodes a thymidine kinase enzyme. In a rate-limiting step, the viral thymidine kinase enzyme converts synthetic nucleoside analogues such as aciclovir, valciclovir and penciclovir to their monophosphate form. Cellular enzymes complete the conversion of the nucleoside monophosphate to the biologically active triphosphate form. DNA-polymerase preferentially incorporates the toxic synthetic nucleoside triphosphate into DNA leading to the premature termination of the DNA (100).

In contrast to lytic EBV-disease, EBV-associated lymphoproliferations are unaffected by aciclovir or ganciclovir, because these EBV-infected lymphocytes do not express the viral thymidine kinase (101). Without the conversion into the monophosphate form, which depends on the viral thymidine kinase, these drugs can not enter their biologically active triphosphate form.

Foscarnet is active in EBV-associated lymphoproliferations due to the ability to bypass the monophosphorylation by the viral thymidine kinase. The drug directly acts against the DNA-polymerase without any prior intracellular phosphorylation (102). This direct more unspecific attack towards the DNA is responsible for the higher rate of toxicity due to the treatment with foscarnet.

Oertel et al. reported in 1999 and 2002 about patients with PTLD who regressed completely after treatment with foscarnet, even without concomitant reduction of immunosuppression in one case (88, 103).

**Monoclonal antibodies (mABs):** Benkerrou et al (22) reported about treatment in 31 patients after solid organ transplantation with a combination of the mABs CD21 and CD24, which are currently not available. The study group showed that this form of treatment was well tolerated and was effective especially in polymorphous lesions. Recently the monoclonal antibody directed against the CD20 antigen –rituximab- was introduced for treatment of indolent B-NHL and in combination with CHOP in aggressive B-NHL. A retrospective study proved, that rituximab in PTLD showed high response rates of 67% for single therapy with rituximab (98). Preliminary results of a phase II trial with 55 patients, which was presented at the 2002 Lugano lymphoma meeting could not validate this high response rates in patients with PTLD treated in first line with rituximab monotherapy. In this trial 11 patients with PTLD following hematopoietic stem cell transplantation and 44 patients with PTLD after solid organ transplantation were included. At day 80, 23 patients (46%) achieved a response (16 complete remissions and 7 partial remissions). 27 patients (54%) either died (7 patients) or progressed. A second multicentre phase II trial, which will be presented at the annual meeting of ASH 2002, investigated rituximab monotherapy in 25 patients with PTLD. Transplantations were performed in kidney (n=7), lung (n=6),

heart (n=6), liver (n=5) and kidney/pancreas (n=1). Rituximab was given as 1<sup>st</sup> line therapy in 15, 2<sup>nd</sup> line in 8 and 3<sup>rd</sup> line in 2 patients. In total 13 patients. (52%) achieved a complete remission (CR) with a mean duration of 25.1 months. The rate of CR did not differ between 1<sup>st</sup> line (55.3%), and 2<sup>nd</sup> line (50%) therapy with rituximab. Partial remission was observed in 1 patient, minor remission in 2 patients, no change in 8 patients and 1 patient experienced progressive disease. Overall response rate is 64%. Early relapse (3, 6 and 12 months) occurred in 3 patients after CR (23%). 2 patients were in CR after 1<sup>st</sup> line therapy and 1 patient after 2<sup>nd</sup> line therapy. The conclusion is that the monoclonal antibody rituximab is equally effective in 1<sup>st</sup> line and in 2<sup>nd</sup> line therapy of PTLD. Due to the rate of early relapse (23%) combination of therapy with cytotoxic drugs is to be evaluated.

**Cytotoxic treatment:** Different cytotoxic regimens that have been employed in the treatment of NHL have also been used in the therapy of PTLD (73,81). So far CHOP chemotherapy is considered to be the goldstandard in PTLD. But there are no results concerning prospective comparative trials available. Mamzer-Bruneel MF (99) treated 10 patients with PTLD after kidney transplantation with CHOP. They report: 6 complete remissions, 2 partial remissions and 2 treatment related death. Garrett et al. (81) reported on four patients, who achieved CR after treatment with CHOP. Garrett et al. (81) came to the conclusion that PTLD are sensitive to chemotherapy and that the side effects are acceptable in most cases, but fatal complications are also described. (68,73,87).

## 1.2. Drug background

### 1.2.1 Preclinical data of rituximab

#### 1.2.1.1 SPECIFICITY AND MODE OF ACTION

The chimeric murine/human anti-CD20 monoclonal antibody rituximab is a human gamma 1, kappa-antibody with variable regions isolated from a murine anti-CD20 monoclonal antibody. This chimerical antibody is produced by the transfected Chinese hamster ovary (CHO) clone 8-8F12-5E5-50C9, and binds to CD20-positive cells with high affinity. The antibody is effective in *in vitro* models and has been shown to deplete B cells *in vivo* (89).

CD20 is expressed on normal B cells, most malignant B cell lymphoma cells and on chronic lymphocytic leukemia cells. CD20 is essential for the regulation of the cell cycle and cell differentiation(90).

The mode of action of rituximab comprises complement-mediated lysis of B cells. Moreover, it involves antibody-dependent cellular cytotoxicity (ADCC). Other potential mechanisms of rituximab against B cells include induction of apoptosis, blockade of G/S-transmission, blockade of differentiation and increase in the phosphorylation of cellular proteins (89).

#### 1.2.1.2 PRECLINICAL DATA ABOUT TOXICITY AND PHARMACOLOGY

Application of high doses of rituximab in Cynomolgus monkeys did not result in significant adverse events. Doses up to 20 mg/kg, administered weekly for 8 weeks, did not lead to toxicity or abnormal histopathological results. As expected, the treated monkeys showed a severe B cell depletion in peripheral blood, the lymph nodes, bone marrow and the spleen. Three weeks after rituximab had been administered

weekly 4 times, a 75% decrease of B cells in bone marrow was found. An increase of B cells in the peripheral blood was observed approximately 60 days after the last dose of the antibody.

### 1.2.2 Clinical data of rituximab

First clinical experiences were done in non-transplanted patients with indolent lymphomas. In a clinical phase I study, a dose escalation of rituximab monotherapy was investigated in relapsed, predominately low-grade lymphomas. Rituximab was administered intravenously at doses of 10, 50, 100, 250, or 500 mg/m<sup>2</sup> in groups of at least 3 patients per dose step. Therapy-associated adverse events correlated with the number of CD20 cells in the peripheral blood and comprised fever (n=5), erythema (n=4), nausea (n=2), chills (n=2), orthostatic hypotension (n=1) and bronchospasm (n=1). During a follow-up of 3 months, no further adverse events were observed (89).

Serological investigations of complement factors and antibody levels showed no significant changes. Furthermore, the levels of platelets, granulocytes, and T cells remained unchanged. In contrast, after application of rituximab, CD20-positive B cells decreased rapidly within 24 – 72 hours. Strongly reduced numbers of CD20-positive B cells persisted for 2 to 3 months after the end of the therapy. In 6 out of 9 patients evaluable for response, the lymphoma responded after application of a single dose of rituximab.

On the basis of these encouraging results, a subsequent phase I/II trial in patients with relapsed B-cell lymphomas investigated the weekly administration of rituximab for the duration of 4 weeks. Doses of 125, 250, and 375 mg/m<sup>2</sup> were applied. The aim of this trial was to examine the accumulation of anti-CD20 antibody and to evaluate the deposition of rituximab in the lymph nodes. Twenty patients were enrolled into the phase I trial. A dose-dependent toxicity was not observed, even at the maximal dose of 375 mg/m<sup>2</sup>(91).

Pharmacological investigations revealed a half-life of rituximab of 1.9 days after the first and 7.8 days after the fourth infusion. The B cells in peripheral blood decreased rapidly. No significant alterations of immunoglobulin serum concentrations were recorded.

Of 18 patients evaluable for response, 11 responded to therapy, 7 with a partial remission and 4 with a minor response.

On the basis of these two phase I studies, the biological active and well tolerated antibody dose of 375 mg/m<sup>2</sup> administered weekly for 4 weeks was chosen for the further enrolment of patients. Altogether, 34 patients with relapsed advanced low-grade lymphomas were studied.

Adverse events were observed only during the first administration of the antibody, and comprised chills, fever, nausea, vomiting, and erythema. The adverse events, however, were only of low intensity.

Of 34 patients evaluated for response, 17 responded to therapy, which comprised 3 complete and 14 partial remissions. The median duration of remission was 10.2 months and exceeded 20 months in 5 out of 17 responders (three are still ongoing at 24+, 27+ and 28+ months).

A single agent multicenter phase II pivotal trial completed patient entry in March 1996. Data on a total of 166 patients with relapsed low-grade or follicular lymphoma, who received single-agent outpatient therapy with IDEC-C2B8/rituximab at 375 mg/m<sup>2</sup> weekly for 4 infusions are available. Most patients were stage III/IV (78%) and had received a median of 2 regimens prior to enrolment in the study. Median number

of former relapses was 2. Also, eight patients had progressed after allogeneic bone marrow transplantation (ABMT). There was a rapid onset of response (within 7 weeks), and responses were also documented in patients with bulky and extranodal disease. On an intent to treat basis, the results of the 156 patients evaluated for efficacy, the overall response was 50% (76/156; 12% CR, 34% PR). The response rate was not affected by age, e.g. similar in patients above or below 60 years. Seven of 22 patients, who were resistant to different chemotherapies, responded to the antibody. The response rate of those patients who were resistant to their last chemotherapy was 34% (15/49) and 53% (65/112) in those who responded to their last chemotherapy. Among patients who had relapsed following ABMT, 78% (18/23) responded to treatment with rituximab. Median time to progress for responders has not been reached (13+ months median follow-up). Rituximab is well tolerated and does not impair the bone marrow reserve (92).

Even more promising results of a combination regimen with rituximab and cytostatic regimens are now available. A phase II study with rituximab in combination with CHOP chemotherapy has been initiated in patients with low-grade or follicular B-cell lymphomas, mainly stages III/IV. To date 32 patients have been treated. The response rate is 100% with complete remissions in 66% of patients. Most patients responded after 40 to 45 days. Only a few patients responded after more than 3 months. The combination therapy with rituximab/CHOP is well tolerated. Adverse events occurred as expected for CHOP chemotherapy alone. Six out of 7 Bcl-2-positive patients became negative after the end of the therapy (93).

In 2002 a randomized trial was published which compared CHOP chemotherapy plus rituximab with CHOP alone in elderly patients with diffuse large-B-cell lymphoma. 197 patients received eight cycles of CHOP and 202 patients received eight cycles of CHOP plus rituximab given on day 1 of each cycle. The rate of complete response was significantly higher in the group that received CHOP plus rituximab than in the group that received CHOP alone (76 percent vs. 63 percent,  $P=0.005$ ). With a median follow-up of two years, event-free and overall survival times were significantly higher in the CHOP-plus-rituximab group ( $P<0.001$  and  $P=0.007$ , respectively) (104).

Several cases or small series reported about successful rituximab therapy in patients with PTLN after heart, lung, liver or kidney transplantation (94, 105, 106, 107). In 1999 a retrospective phase II study was published. Twenty-six patients had undergone solid organ transplants (liver 8, kidney 8, heart 4, lung 3, heart lung 1, kidney-pancreas 1, liver-kidney 1). The response rate was 67% (15 CR and 2 PR). With a median follow-up of 8 months (1-16 months) 24 patients are still alive. The one-year projected survival was 73%. 11 patients were alive with no evidence of disease, 4 patients relapsed a median of 7 months (3-10 months) after treatment and 3 died while in CR of concurrent diseases (98).

Preliminary results of a phase II trial with 57 patients, which were presented at the 2002 Lugano lymphoma meeting could not validate this high response rates in patients with PTLN treated in first line with rituximab monotherapy. In this trial 11 patients with PTLN following hematopoietic stem cell transplantation and 46 patients with PTLN after solid organ transplantation were included. At day 80, 23 patients (46%) achieved a response (16 complete remissions and 7 partial remissions). 27 patients (54%) either died (7 patients) or progressed. Secondly it seems that in a relevant part of patients the remissions are of limited duration. A second multicentre phase II trial, which will be presented at the annual meeting of ASH 2002, investigated rituximab monotherapy in 25 patients with PTLN. Transplantations were performed in kidney (n=7), lung (n=6), heart (n=6), liver (n=5) and kidney/pancreas

(n=1). Rituximab was given as 1<sup>st</sup> line therapy in 15, 2<sup>nd</sup> line in 8 and 3<sup>rd</sup> line in 2 patients. In total 13 patients. (52%) achieved a complete remission (CR) with a mean duration of 25.1 months. The rate of CR did not differ between 1<sup>st</sup> line (55.3%), and 2<sup>nd</sup> line (50%) therapy with rituximab. Partial remission was observed in 1 patient, minor remission in 2 patients, no change in 8 patients and 1 patient experienced progressive disease. Overall response rate is 64%. Early relapse (3, 6 and 12 months) occurred in 3 patients after CR (23%). 2 patients were in CR after 1<sup>st</sup> line therapy and 1 patient after 2<sup>nd</sup> line therapy. The conclusion is that the monoclonal antibody rituximab is equally effective in 1<sup>st</sup> line and in 2<sup>nd</sup> line therapy of PTLD. Due to the rate of early relapse (23%) combination of therapy with cytotoxic drugs is to be evaluated.

### **1.3 Clinical data of CHOP chemotherapy**

Single center reports exist concerning CHOP chemotherapy in patients with PTLD. Mamzer-Bruneel MF (99) treated 10 patients with PTLD after kidney transplantation with CHOP. The results were: 6 complete remissions, 2 partial remissions and 2 treatment related deaths. Garrett et al. (81) reported on four patients, who achieved CR after treatment with CHOP. They concluded that PTLD is sensitive to chemotherapy and that the side effects are acceptable in most cases, but fatal complications are also described. (68,73,87). This fatal complications are due to an enhanced haematotoxicity, which is caused by the toxic side effects of immunosuppressive drugs on kidney- and bone marrow- function. Further, these patients are higher susceptible for infectious even septic complications, due to the impaired immune system.

### **1.4 Rationale for performing the present study**

The rationale for performing the present study is to combine two highly active treatment modalities in first line therapy of solid organ recipients with B-cell PTLD.

The monoclonal antibody CD20 represents an effective therapeutic approach in the treatment of PTLD. Unfortunately this effect seems to be of limited duration in some patients, who benefited from monotherapy with rituximab.

The advantage of this therapeutic approach in PTLD is due to the low incidence of third to fourth degree adverse events. At diagnosis of PTLD a relevant proportion of these patients is not suitable for first line cytotoxic chemotherapy due to widespread disease, organ dysfunction or reduced performance state. Insufficiencies of kidney- or bone marrow function are frequent in organ recipients due the toxic side effects of the immunosuppressive drugs.

After pre-phase treatment with the monoclonal antibody rituximab the CHOP chemotherapy is suggested to be less toxic due to the lower tumor burden.

Thereby treatment related severe or even lethal toxicities, frequently reported in patients with PTLD who underwent cytotoxic chemotherapy, may be prevented. Furthermore the total number of cytotoxic cycles of CHOP-therapy is reduced from 6 or 8 to 4 cycles and thus may result in an additional reduction of toxicity in the single patient.

## **2. Study Objectives**

This phase-II trial will investigate the efficacy, safety and the tolerability of a sequential therapy consisting of rituximab antibody followed by CHOP chemotherapy in patients with CD20+ Post-transplant lymphoproliferative disorders (PTLD).

### **2.1 Primary objectives**

The primary objective is the evaluation of the efficacy of a sequential therapy consisting of rituximab antibody followed by CHOP chemotherapy to induce remission in CD20+ PTLT. For this aim the overall objective response rates after therapy = complete and partial response and the duration of the response will be measured.

### **2.2 Secondary objectives**

The secondary objective is to determine the adverse events and tolerability of a sequential therapy consisting of rituximab antibody followed by CHOP chemotherapy in CD20+ PTLT. Furthermore, the long-term safety will be determined, especially the frequency of complicating infections and the overall survival.

## **3. Study Duration and Study Termination**

This is a multicenter, open phase II study. The start of the study is planned for January 2003.

It has been estimated that 2-5 patients develop lymphoproliferative disorders, associated to solid organ transplantation per year, in centers with 100–200 transplantations a year. Patient recruitment should not exceed 12 months. The follow-up period will be restricted to another 24 months. So, the total study duration will be about 36 months.

If the study is terminated prematurely, the reasons must be documented. All patients enrolled at that time have to be documented by the investigators. All data are collected and a descriptive analysis is performed. The results have to be summarized in a final report.

## **4. Participating Centers**

Klinik für Innere Medizin mit Schwerpunkt Hämatologie und Onkologie, Charité Campus Virchow, Medizinische Fakultät der Humboldt Universität Berlin, Augustenburger Platz 1, 13353 Berlin

Prof. Dr. H. Riess, Dr. med R. Trappe, Prof. Dr. B. Dörken

Allgemein und Transplantationschirurgie, Charité Campus Virchow, Medizinische Fakultät der Humboldt Universität Berlin, Augustenburger Platz 1, 13353 Berlin

P.D. Dr. S. Jonas, Prof. Dr. P. Neuhaus

Thoraxchirurgie, Deutsches Herzzentrum Berlin, Augustenburger Platz 1, 13353 Berlin

Dr. med S. Kapell, P.D. Dr. M. Hummel, Prof. Dr. R. Hetzer

Medizinische Klinik mit Schwerpunkt Nephrologie, Charité Campus Mitte,  
 Medizinische Fakultät der Humboldt-Universität Berlin,  
 Schumannstr 20/21, 10117 Berlin  
 Dr. med K. Budde, Prof. Dr. Hans-H. Neumayer

Medizinische Klinik mit Schwerpunkt Nephrologie und Internistische Intensivmedizin,  
 Charité Campus Virchow, Medizinische Fakultät der Humboldt Universität Berlin,  
 Augustenburger Platz 1, 13353 Berlin  
 Dr. med N. Babel, Prof. Dr. U. Frei, Prof. Dr. P. Reinke

Medizinische Klinik II, Klinikum Oldenburg, Dr.-Eden-Str.10, 26133 Oldenburg  
 Dr. med U. Metzner

Institut für Pathologie, Universitätsklinikum Benjamin Franklin,  
 Hindenburgdamm 30, 12200 Berlin  
 PD Dr. I. Anagnostopoulos, Prof. Dr. H. Stein

Division of Clinical Pathology, Hôpitaux Universitaires de Genève,  
 Rue Michel Servet 1, 1211 Geneva; Switzerland  
 Prof. Dr. B. Borisch, D.M. Tinguely

Dept.of Medicine I, Div. of Hematology and Hemostaseology, Universtiät Wien, AKH,  
 Währinger Gürtel 18-20, A- 1090 Wien  
 Prof. U. Jaeger

Service d'Hématologie, Hôpital Pitié-Salpêtrière, 47 Bld de l'Hôpital,  
 F-75013 Paris, France  
 Dr. V. LeBlond, Dr. S. Choquet

Service d'Hématologie, CHU Hôtel-Dieu, Place Alexis Ricardeau,  
 F-44093 Nantes, France  
 Dr. N. Milpied

Service d'Hématologie Biologique, Hôpital Avicenne, 125 Bld. De Stalingrad,  
 F-93009 Bobigny cedex, France  
 Dr. Martine Raphael, Dr. H. Poirel,

Haematology and Oncology, Sahlgrenska University Hospital,  
 SE-41345 Gothenburg Schweden  
 Dr. T. Ekman, Dr. M. Sender

Haematology and Oncology, L'Hospitalet de Llobregat Barcelona, Spain  
 Dr. A. F. de Sevilla, Dr. E. Gonzalez-Barca

## **5. Selection Criteria**

### **5.1 Total number of patients**

One hundred patients will be enrolled in the study in order to evaluate primarily the efficacy and second the safety and tolerability of a sequential therapy consisting of rituximab antibody followed by CHOP chemotherapy.



## **5.2 Study population**

Female or male patients with proven, measurable PTLD after solid organ transplantation (e.g. heart, lung, liver or kidney etc.). Patients having PTLD with or without EBV association, positive for CD20, with treatment failure after the reduction of immunosuppression with or without antiviral therapy.

## **5.3 Inclusion criteria**

- PTLD with or without EBV association, confirmed after biopsy or resection of tumor.
- Measurable disease of > 2 cm in diameter and/or bone marrow involvement.
- Patients having undergone heart, lung, liver, kidney, pancreas, small intestine transplantation or other or a combination of the organ transplantations mentioned.
- Karnofsky scale >50% or ECOG = 3.
- Reduction of immunosuppression with or without antiviral therapy.
- A complete surgical extirpation of tumor was not performed.
- A radiation therapy was not performed.
- Effective contraception for women in childbearing age.
- Patient's written informed consent and written consent for data collection.
- Patients are > 18 years (or =15 years with parental agreement ).

## **5.4 Exclusion criteria**

- Life expectancy less than 6 weeks.
- Karnofsky-scale <50% or ECOG =3
- Treatment with rituximab before.
- Known allergic reactions against foreign proteins
- Concomitant diseases, which exclude the administration of therapy as outlined by the study protocol.
- non-compensated heart failure.
- Dilatative cardiomyopathy.
- Myocardial infarction during the last 6 months.
- Severe non-compensated hypertension.
- Severe non-compensated diabetes mellitus.
- Renal insufficiency (creatinine more than 3-fold of the upper normal value), not related to lymphoma.
- Hepatic insufficiency with transaminase values greater than 3-fold of the normal values and/or bilirubin levels >3.0 mg/dl, not related to lymphoma.
- Clinical signs of cerebral dysfunction.
- Women during the lactation period, pregnant or of childbearing potential not using a reliable contraceptive method.
- Involvement of the central nervous system by the disease.
- Severe psychiatric disease.
- Known to be HIV positive.
- Missing written informed consent of the patient.

## **5.5 Admission to study**

The patients meeting the study entry criteria are reported to the study's head office. Patients have to be informed about possible risks and consequences of the therapy. Patients have to give their written informed consent to participate in the study. The study office can be contacted via:

tel.: 0049 (0) 30-450553510, fax: 0049 (0) 30-450553901,

e-mail: ralf.trappe@charite.de or mail: PTLD study office, Dr. med. R. Trappe, Hämatologie, Universitätsklinikum Charité-Campus Virchow, Humboldt Universität Berlin, Augustenburger Platz 1, Mittelallee 11, 13353 Berlin, Germany.

## 6. Disease Evaluation (Efficacy Criteria)

### 6.1 Diagnostics

#### 6.1.1 DIAGNOSTICS PRIOR TO ONSET OF THERAPY

In order to include the patient in this study, histological confirmation of the diagnosis is necessary and should include CD20 antigen detection. In some rare cases cytological confirmation of the diagnosis will be sufficient. For confirmation of histological diagnosis and classification according the WHO classification, referral pathologists should be supplied with material embedded in paraffin and with fresh material (Appendix F). All cases should be reevaluated at one of the three institutes of pathology (Berlin, Geneve, Paris). The following table presents investigations needed for the estimation of the stage of the lymphoproliferative disease, the patient's state of immunity and for the evaluation of remission of disease.

Assesment	Initial diagnostics
Malignant disease/treatment history	X
Demographic data	X
Concomitant diseases and treatment	X
Recent clinical history (B symptoms)	X
Physical examination	X
ECOG-Zubrod scale	X
Biopsy/resection*	X
Chest X-ray	X
Abdominal ultrasound	(X)
Cervical ultrasound	(X)
Ultrasound examination of peripheral lymph node regions	(X)
Ultrasound of small and large intestine	(X)
Cranial CT	X
Thorax CT	X
Abdominal CT	X
Bone marrow biopsy and bone marrow aspiration	X
Endoscopy	(x)
Cytology of cerebrospinal fluid (if neurological abnormalities)	X
Complete and differential blood count	X

Immunophenotyping of peripheral mononuclear cells	X
Complete laboratory investigations (incl. sodium, potassium, calcium, phosphate, creatine, urea, uric acid, total protein, protein electrophoresis, quantitative analysis of serum immunoglobulins, transaminases, alk. phosphatase, bilirubin, LDH, $\beta_2$ -microglobulin, PTT, PT, ATIII, monoclonal $\gamma$ -pathy in serum)	X
ECG	X
Peripheral blood for quantitative EBV-PCR analysis (see appendix G)***	X
30 ml of heparinized blood for analysis of EBV-specific T-cell immunity (Charité-Campus Virchow, Forschungshaus Labor Dr. M. Subklewe Augustenburger Platz 1, 13353 Berlin, Germany or Paris for french teams)**	X
Hepatitis B + C serology	X
CMV-PCR+antigen	X
EBV serology	X
Immunstate <sup>1</sup>	X

**Table I.**

( ): The investigations in parentheses are to be performed, if necessary for the determination of the stage of disease, of remission or complications.

<sup>(1)</sup> obligatory: CD3+CD4+; CD3+CD8+; CD19+ or CD20+\*\*.

Please send samples per express mail or per Express-Service (e.g. TNT).

\* Biopsy / resection and/or frozen effusion cells :

They should be reviewed by a panel of expert hemopathologists.

Paraffin-embedded (formol and / or PFA fixation) and frozen samples should be performed. A frozen fragment of at least 0.5cm<sup>3</sup> will be used both for DNA extraction (CGH / CGH-array and micro-satellite instability) and RNA extraction (cDNA-array).

\*\* Complementary panel :

differentiation markers : Bcl6, IRF4, CD138,

EBV detection : LMP1, EBNA2 and EBERs (in situ hybridization)

apoptosis : Bcl2

proliferative index : Ki-67

\*\*\* : Micro-satellite instability study needs peripheral blood samples. But it could be performed on this sample (less than 0.5 $\mu$ g DNA is required) if possible.

### 6.1.3 Diagnostics during and after therapy

During the infusion of the antibody, vital signs should be monitored every 15 minutes, as well as 30 minutes and 60 minutes after the end of the infusion.

Every week before application of the antibody and every day 1 of each CHOP cycle before application of chemotherapy.

Recent medical history and physical examination,  
complete and differential blood counts, and  
Laboratory tests

The table II below shows diagnostics during treatment and at re-staging day 50 and 144 and during follow up.

Assessment	day 8,15,22,72, 94,116	Diagnostics day 50, 144 and during 2 years
Recent clinical history (B symptoms)	X	X
Physical examination	X	X
Karnofsky / ECOG scale	X	X
Chest X-ray		X
thorax, abdominal and pelvis CT		X
Cervical ultrasound		(x)
Ultrasound examination of peripheral lymph node regions		(x)
Ultrasound of small and large intestine		(x)
Cranial CT		(x)
Bone marrow biopsy and bone marrow aspiration		(x)
Endoscopy		(x)
Complete and differential blood count	X	X
Immunophenotyping of peripheral mononuclear cells		(x)
Complete laboratory investigations (incl. sodium, potassium, calcium, phosphate, creatine, urea, uric acid, total protein, protein electrophoresis, quantitative analysis of serum immunoglobulins, transaminases, alk. phosphatase, bilirubin, LDH, $\beta_2$ -microglobulin, PTT, quick, ATIII, urine analysis)	X	X
monoclonal $\gamma$ -pathy in serum,	(x)	(x)
Peripheral blood for quantitative EBV-PCR analysis (see appendix G)	X	X
30 ml of heparinized blood for analysis of EBV-specific T-cell immunity (Charité-Campus Virchow, Forschungshaus Labor Dr. M. Subklewe Augustenburger Platz 1, 13353 Berlin, Germany or Paris for french teams )	X	X
Immunstate <sup>1</sup>	X	X

**Table II.**

( ) : The investigations in brackets are to be performed, if necessary for the determination of the stage of disease, of remission or complications.

<sup>(1)</sup> obligatory: CD3+CD4+; CD3+CD8+. CD19+ or CD20+.

Please send samples per express mail per Express-service (e.g. TNT).

### *6.1.2.1 Measurement of EBV viral load in peripheral blood*

Samples to measure the EBV viral load should be taken at every visit of patients. The measurement is centralized at “Institut für Medizinische Mikrobiologie und Hygiene, Abt. Virologie, Universitätskliniken des Saarlandes, Haus 47, D-66421 Homburg” (please see Addendum G).

### 6.1.3 *Criteria for evaluation*

Criteria of response are those of the WHO for lymphoproliferative diseases.

**Complete remission (CR):** Complete regression of all objective findings of lymphoproliferative disease at the time of restaging for at least 4 weeks. In case of previous involvement of the bone marrow any persisting infiltration of the bone marrow must be ruled out.

**Partial remission (PR):** Regression of more than 50% of all manifestations of lymphoproliferative disease (sum of the products of two diameters perpendicular to each other, measuring the size of a manifestation) for at least 4 weeks without the appearance of new manifestations of the disease.

**Stable disease (SD):** <50% regression of all manifestations of lymphoproliferative disease. No CR, PR or PD. <25 % progression for at least 4 weeks.

**Progression (PD):** Increase of frequency and severity of symptoms of disease; appearance of new nodal and extranodal manifestations of lymphoproliferative disease; increase in size of previous manifestations >25%; increase of splenomegaly >25%.

**Relapse:** Occurrence of parameters as described for progression (PD) in patients in remission (i.e. after CR or PR).

**Duration of remission:** Time between the date of best response (complete or partial) and relapse or progression.

**Time to progression:** Interval between start of treatment and detection of progressive disease.

## 6.2 *Assessment of efficacy*

Diagnostics are indicated in tables I and II. Diagnostics have to be performed during the 3 weeks prior to therapy; weeks 1 to 4 during the application of rituximab; before administration of each of the 4 cycles CHOP chemotherapy; four weeks after the end of therapy; during the months 6 to 24.

### 6.2.1 *Primary efficacy parameter*

The primary efficacy parameter is:  
response rate (CR + PR)

### 6.2.2 *Secondary efficacy parameter(s)*

Further efficacy parameters are:

1. duration of response, and
2. time to progression.
3. overall survival

## 6.3 *Assessment of safety*

During each visit of the patient, potential side effects are monitored and documented.

The following parameters are evaluated:

1. number, severity and causality of adverse events,
2. vital signs,
3. laboratory tests, and
4. number of infections following rituximab application.

## 7. Study Treatment

### 7.1 Treatment plan

Rituximab will be administered as a single therapeutic agent at a standard dosage of 375 mg/m<sup>2</sup> infused intravenously once a week for 4 weeks at days 1, 8, 15 and 22. CHOP chemotherapy will be administered at a standard dose of cyclophosphamid 750 mg/m<sup>2</sup>, adriamycine 50 mg/m<sup>2</sup>, vincristine 1.4mg/m<sup>2</sup> and prednisone 50mg/m<sup>2</sup> infused intravenously (except prednisone which is administered orally) every 3 weeks at days 50, 72, 94 and 116.

In case of disease progression during administration of rituximab antibody or the 4 weeks interval between antibody and CHOP administration the patients directly enter the CHOP chemotherapy.

#### 7.1.1 Concomitant medications during rituximab

Acetaminophen and diphenhydramine hydrochloride. Prior to rituximab infusion, pretreatment should be applied with acetaminophen (1000 mg) and diphenhydramine hydrochloride (50 to 100 mg).

Allopurinol or Fasturtec. In case of hyperuricemia allopurinol will be applied according to each study center's policy. Prior to first antibody application, pretreatment with allopurinol has to be performed.

Corticosteroids. Corticosteroids should not be applied during this trial except in the context of immunosuppression or in the case of treatment of rejection. Before or during rituximab infusion corticosteroids are only allowed when very severe or life-threatening allergic reactions occur. Patients must not be administered pretreatment (prophylactically, prior to rituximab treatment) dexamethasone or any other glucocorticoid.

Antibiotics and G-CSF. No prophylactic or standardized application of antibiotic or of growth factors is scheduled.

Others. Patients should receive full supportive care including transfusions of blood and blood products, antibiotics, anti-emetics, etc., where applicable.

## Concomitant medications during CHOP chemotherapy

Antibiotics. The patients receive prophylactic antibiotics:

bactrim twice daily p.o.

ciprofloxacin 500mg twice daily p.o.

according to each center policy.

The prophylaxis should be applied till recovery of neutrophil granulocytes after every cycle.

Allopurinol or fasturtec: In case of hyperuricemia allopurinol will be applied according to each study center's policy.

Antiemetics: At day 1 of each cycle CHOP chemotherapy a antiemetic treatment should be applied: e.g. ondansetron 4-8 mg i.v. or tropistron 5mg i.v.

G-CSF. The use of G-CSF after CHOP chemotherapy is obligatory. A single dose of 6 mg pegfilgrastim (Neulasta ®) s.c. has to be injected on day 3. Alternatively filgrastim 5 µg/kg bodyweight can be injected daily s.c. from day 3 for a duration depending on each center policy.

Others. Patients should receive full supportive care including transfusions of blood and blood products, antibiotics, anti-emetics, etc., where applicable.

### 7.1.2 Dosage and rationale for application of rituximab

#### 7.1.2.1 PREPARATION OF RITUXIMAB

375 mg of CD20 mAB is diluted in 0.9% NaCl to a maximum concentration of 1 mg/ml. The solution must be handled carefully, as shaking may cause aggregation and precipitation of the antibodies.

#### 7.1.2.2 APPLICATION OF RITUXIMAB

Rituximab is allowed to be administered in an out-patient facility. However, it is recommended that the first infusion is performed on a regular ward.

The application of CD20 mAB rituximab may lead to the rapid destruction of tumor cells, which can make sufficient hydration and prophylaxis with allopurinol/fasturtec necessary.

### **CD20 mAB rituximab must not be given intravenously in a bolus.**

Thirty to 60 minutes before the infusion of CD20 mAB, treatment with acetaminophen (1000 mg, facultatively) and 50 to 100 mg diphenhydramine hydrochloride should be started. Concomitant corticosteroids are not allowed unless severe allergic reactions occur.

CD 20 mAB rituximab should be administered via an intravenous or central venous line. Prior to infusion, epinephrine for subcutaneous injection and diphenhydramine hydrochloride for intravenous injection have to be available. Furthermore, all facilities for intervention in case of an anaphylactic reaction must be available.

During infusion, the occurrence of fever (>38.5°C), chills, mucosal swelling and hypotension (drop in blood pressure by >30 mmHg) is possible. In case of those well



known adverse events, infusion of antibody must be interrupted. After the symptoms have disappeared, infusion at half rate can be restarted. The infusion via an infusion pump will start at a rate of 50 mg/h for the first 30 minutes. If no anaphylactic reactions occur, the rate may be increased half-hourly to a total of 400 mg/h. If the first application of rituximab was well tolerated, during the second administration the rate of infusion can start at 100 mg/hour and also half-hourly be increased up to 400 mg/hour.

**Following the infusion the intravenous line should be kept open for medications, as needed. If there are no complications, the intravenous line may be discontinued after one hour of observation.**

The application of CD20 mAB rituximab to patients, who have encountered adverse events after previous applications of proteins (e.g. transfusions of thrombocytes or immunoglobulins), should be considered carefully.

This treatment is repeated on days 8, 15 and 22.

### Dosage: 375 mg/m<sup>2</sup>

Body surface	Total dose
1.4 m <sup>2</sup>	525.0 mg
1.5 m <sup>2</sup>	562.0 mg
1.6 m <sup>2</sup>	600.0 mg
1.7 m <sup>2</sup>	637.5 mg
1.8 m <sup>2</sup>	675.0 mg
1.9 m <sup>2</sup>	712.5 mg
2.0 m <sup>2</sup>	750.0 mg

hours	First application		Further application	
	mg/h*	mg-total	mg/h*	mg-total
0 – 0,5	50	25	100	100
0,5 – 1	100	75	150	175
1 – 1.5	150	150	200	275
1.5 – 2	200	250	250	400
2 – 2.5	250	375	300	550
2.5 – 3	300	525	350	725
3 – 3.5	350	700	400	925
3.5 – 4	400	900		

\* = With a concentration of 1 mg/ml the values of mg/h are equal to ml/h.

#### 7.1.2.3 How to handle side effects during infusion

In the case of mild side effects, continuation of therapy is possible depending on the primary physician's assessment.

If side effects of toxicity grade I or II occur, therapy can be continued without interruption or dose adaptation according to the physician's assessment.

In the case of adverse events of toxicity grades III or IV, infusion of rituximab is interrupted until the side effects have decreased to toxicity grade I.

Therapy restarts according to the physician's opinion. Restart of Infusion after an adverse event should be at half the rate of infusion previously given. If the same adverse event occurs again, therapy is stopped completely.

## **7.2 Cytotoxic treatment - CHOP**

Cytotoxic combination therapy with cyclophosphamide (CPM), adriamycin (ADM), vincristine (VCR) and prednisolone (Pred).

### **Standard dose:**

cyclophosphamide	750 mg /m <sup>2</sup>	i.v. day 1
adriamycine	50 mg /m <sup>2</sup>	i.v. day 1
vincristine	2 mg	i.v. day 1
prednisolone	100 mg	p.o. daily, day 1-5

### **Repeat on day 21**

Four cycles will be applied. If no response to treatment (no change; NC) or progression of disease (PD) is found on the first interim staging investigation before the third cycle of treatment the patient is out of the treatment and can be treated in an individualized way.

### **7.2.1 Toxicity - CHOP**

Treatment with azathioprine or similar antimetabolites has to be finished before cytotoxic treatment according the CHOP regimen can start. Patients receiving immunosuppressive therapy after solid organ transplantation often prove to have insufficiency of the bone marrow activity. That is why G-CSF is administered prophylactically. Depending on the degree of hematotoxicity, which has been evoked by the first cycle of chemotherapy, the following cycles' doses are adapted. Intolerable hematotoxicity WHO IV° must lead to further dose reduction. In case of hematotoxicity WHO III°, which can be tolerated, dosage remains the same. The following tables summarize the dose adaptations in case of different organ insufficiencies:

#### **7.2.2 DOSE ADAPTION DUE TO ORGAN DYSFUNCTION**

##### **Dose adaptation in case of bone marrow insufficiency or bone marrow infiltration**

Leukocytes:	< 2000 / $\mu$ l	reduction of 25 %
Thrombocytes:	< 100000 / $\mu$ l	reduction of 25 %
Leukocytes:	< 1500 / $\mu$ l	reduction of 40 %
Thrombocytes:	< 70000 / $\mu$ l	reduction of 40 %

##### **Dose adaptation in case of impaired liver function:**

Conjugated Bilirubine acts as parameter of impaired liver function, if hemolytic anemia or impairment of extrahepatic secretion has been ruled out.

CPM:		no reduction	
ADM:	Bilirubin (in U/l):	1,1-1,5 mg/ml	reduction of 50 %
		1,6-3,0 mg/ml	reduction of 75 %
		>3,0 mg/ml	no application
VCR:		>1,5 mg/ml	reduction of 50 %
		>3,0 mg/ml	reduction of 75 %

*Dose adaptation in case of impaired renal function:*

CPM:	Creatinine-Clearance	<25 ml/min	reduction of 50 %
		0 ml/min	dialysis
ADM:		no reduction	
VCR:		no reduction	

## 8. Discontinuation of Study

All patients have the right to withdraw their agreement to participate in the study at any time without having to give reasons. The responsible physician has the right to exclude all such patients from the study who suffer from intervening illnesses, in the event of undesirable events, progressive disease (during CHOP therapy), non-haematologic toxicity degree III-IV by the WHO or in the case of disregard of the protocol or for other reasons. If a patient decides to discontinue his participation in the study, all efforts must be made to complete all the investigations as thoroughly as possible and to document all findings.

Therapy must be discontinued under the following circumstances:

- Significant violation of the protocol or non-compliance of the patient or of the responsible person at the respective treatment center.
- Refusal of the patient to participate in any further treatment or investigations.
- Unacceptable or dose-limiting toxicity.
- If the responsible doctor decides to discontinue a patient's participation, because it is medically indicated, consultation with the study's coordinator must take place.
- In case of occurrence of illnesses or complications not associated to the treatment.
- If the patient cannot take part in follow-up examinations.
- Progression of disease.

## 9. Provisional Analysis of the Study

Interim analysis of the study will take place, as soon as 30 patients have completed treatment with rituximab and CHOP chemotherapy, one month after the last CHOP. At this stage, the study's coordinating group decides whether a study meeting is necessary and whether the committee for ethics needs to be informed.

## **10. Informing of Patients and Ethics**

The patients are informed about their disease, the goals, risks and side-effects of therapy, about the special methods of treatment and the basic question of this study, about the voluntary character of participation in the study and the right to withdraw from the study.

The treatment and all diagnostic procedures are performed in accordance with the current version of the Declaration of Helsinki (Appendix D) and in accordance with the laws and regulations of the country in which the study is to be performed, depending on which regulations provide greatest security for the patient.

The patient's agreement must be documented after the goals, methods, possible risks and the expected benefit of the study have been explained to the patient.

The study's protocol, including a copy of the patient's information sheet is presented to the local committee for ethics, by which it must be approved. The committee for ethics must be informed about later alterations of the protocol.

## 12. References

1. Dummer JS et al. Transplantation 1983;36:259-67.
2. Armitage JM et al. J Heart Lung transplant 1991;10:877-87.
3. Penn I et al. Transplant Proc 1969;1:106-12.
4. Penn I et al. Crit Rev Oncogenesis 1989;1:27-52.
5. Penn I et al. transplant Proc 1991;23:1101-3.
6. Gatti RA. Cancer 1971;55:89-98.
7. Filipovich AH et al. In: Margrath IT ed. The Non-Hodgkin's lymphoma. London: Edward Arnold 1990:135- 54.
8. Cunningham-Rundles C et al. J Clin Immunol 1987;7:294-99.
9. Perry GS et al. J Pedeatric 1980;97:72-8.
10. Morrel D et al. JNCI 1986;77:89-92.
11. Ziegler JL et al. In: Margrath IT ed. The Non-Hodgkin's lymphomas. London: Edward Arnold 1990:1990.
12. Zur Hausen et al. Nature 1970;228:1056-8.
13. Hamilton-Dutoit SJ et al. Blood 1993;82:619-24.
14. Klein G. In: Epstein MA, Achong BG eds. The Epstein-Barr Virus. Heidelberg, New York. Springer Verlag 1979:339-50.
15. Pallesen G et al. N Engl J Med 1991;337:320-2.
16. Su IJ et al. Blood 1991;77:799-808.
17. Penn I. N Engl J Med 1990;323:1767-9.
18. Rostaing L et al. Transplant Proc 1995;27:1781-2.
19. Ho M et al. Transplantation 1988;45:719.
20. Frizzera G. In: Knowles DM eds: Neoplastic Hematopathology. Baltimore, Williams and Wilkins 1992:p459.
21. Nalesnik MA et al. Curr Probl Surg 1988;25:371-472.
22. Benkerrou M et al. Blood 1998;92:3137-47
23. Opelz G et al. Lancet 1993;342:1514-6.
24. Hanto DW. Ann Rev of Med 1995;46:381-94.
25. Knowles DM et al. Blood 1995;85:552-6.
26. Frizzera G et al. Cancer Res 1981;41:4253.
27. Oertel S, Jonas S, Hummel M, Anagnostopoulos I, Riess H et al. Onkologie 1997;20(suppl 1):87.
28. Baer I et al. Nature 1984;310:207-11.
29. Swinnen L et al. Blood 1995;9:3333-40.
30. Spencer ES et al. Acta Med Scand 1972;191:107-10.
31. Marker SC et al. J Surgery 1979;85:433-40.

32. Chang RS et al. *N Engl J Med* 1973;289:1325-9.
33. Strauch B et al. *Lancet* 1974;1:234-7.
34. Chang RS et al. *Viol* 1982;10:134-7.
35. Hanto DW et al. *Surgery* 1981;90:204-13.
36. Crawford DH et al. *Lancet* 1980;1:1355-6.
37. Tlsyt T et al. in: Schminke RT ed. *Gene amplification*. Cold Spring Hrbor, New York, Cold Spring Habor Laboratory 1982:231-8.
38. Cleary ML et al. *Blood* 1988;72:349-52.
39. Locker J et al. *Am J Pathol* 1989;6:977-87.
40. Paton DF et al. *Transplantation* 1990;49:1080-4.
41. Ho M et al. *J Infect Dis* 1985;152:876-86.
42. Weiss L et al. *Am J Pathol* 1989;134:651-9.
43. Borisch Chappuis et al. *Am J Pathol* 1990;136:751-8.
44. Thomas JA et al. *Transplantation* 1990;49:94-53.
45. Young L et al. *N Engl J Med* 1989;312:1080-5.
46. Tosato G et al. *Adv Immunol* 1985;37:99-149.
47. Skare J et al. *J Virol* 1985 1985;55:286-97.
48. Wang D et al. *J Virol* 1988;62:2337-46.
49. Birkeland SA et al. *Scand J Urol Nephrol* 1983;17:355-9.
50. Thorely-Lawson et al. *Proc Natl Acad Scien USA* 1987;84:5384-8.
51. Murray RJ et al. *J Virol* 1988;62:894-901.
52. Henle G et al. *J Infect Dis* 1974;130:321-9.
53. Blazar B et al. *J Exp Med* 1980;151:614-27.
54. Miller G. *J Infect Dis* 1990;833:839-44.
55. Fahey JL et al. *Ann Intern Med* 1987;106:257-274.
56. Gaston JSH et al. *Lancet* 1982;1:923-5.
57. Legendre CM et al. *Transplantation* 1986;42:347-52.
58. Ren EC et al. *Transplantation* 1988;45:988-9.
59. Kahan BE. *N Engl J Med* 1989;321:1725-38.
60. Kunkl A et al. *Immunol* 1980;125:2526-31.
61. Roberts MS et al. *Transplantation* 1990;50:91-5.
62. Krönke M et al. *Proc Natl Acad Sci USA* 1084;81:5214-8.
63. Granelli-Piperino A et al. *A , J Exp Med* 1986;163:922-37.
64. Zutter MM et al. *Blood* 1988;72:520-9.
65. Shapiro RS et al. *Blood* 1988;71:1234-43.
66. Rady P et al. *Lancet* 1995;345:1339-40.

67. Swinnen L et al. *N Engl J Med* 1990;323:1723-8.
68. Starzl TE et al. *Lancet* 1984;1:583.
69. Riess H. *Ann Hem* 1996;73:163-7.
70. Hanto DW et al. *N Engl J Med* 1982;306:913.
71. Hanto DW et al. *Transplant Proc* 1985;17:89-92.
72. Hanto DW et al. *Transplantation* 1985;39:461-72.
73. Oertel S, Riess H. *Acta hematol* 1997;98 (suppl 1);25.
74. Pirsch G et al. *Am J Med* 1989;86:241-4.
75. Bo Öberg S. *Pharmac Ther* 1989;2:213-285.
76. Lewin G et al. *Int J Cancer* 1987;39:472-6.
77. Prachowa M et al. *Acta Virol* 1983;27:329-36.
78. Ahlmen L et al. *Scand J Urol Nephrol* 1985;92:41-4.
79. Ringden J et al. *Proc 14th Int Chemo Meet* 1985.
80. Ringden J et al. *Lancet* 1985;13:1503-4.
81. Garret S et al. *Cancer* 1993;72:2782-7.
82. Levine R et al. *Blood*;78:3148-54.
83. Miles T et al. *Blood* 1991;77:2109-17.
84. Scadden E et al. *Sem Hematol* 1992;29:33-7.
85. Gerhartz H et al. *Blood* 1993;82:2329.
86. Igarashi J et al. *Proc ACSO* 1997;16:154.
87. Oertel S, Jonas S, Riess H et al. *Onkologie* 1997;20(suppl 1):87
88. Oertel S, Ruhnke M, Anagnostopoulos I et al. *Transplantation* 1999; 67(5): 765
89. Maloney DG, Liles TM, Czerwinski CK et al. *Blood* 1994;84:2457-66
90. Tedder TF and Engel P. *Immunology Today* 1994;15:450-4
91. Maloney DG, Grillo-Lopez AJ, Bodgkin DJ et al. *J Clin Oncol* 1997;15:3266-74
92. McLaughlin P, Grillo-Lopez AJ, Czuczman M et al. *Am Soc Clin Oncol* 1997;16 abstract 55
93. Czuczman M, Grillo-Lopez AJ, Saleh M et al. 1996, EORTC/NCI meeting Amsterdam.
94. Oertel SH, Anagnostopoulos I, Riess H et al. *Transplantation* (accepted)
95. Oertel SH, Riess H. *Recent Results Cancer Res* 2002;159:89-95
96. Harris NL, Swerdlow SH, Frizzera G, Knowles DM. In: Jaffe ES, Harris NL, Stein H, Vardiman JW, eds. *World Health Organization Classification of Tumours. Pathology and Genetics of Tumours of Haematopoietic and Lymphoid Tissues*. IARC Press; 2001:264-269.
- 97 Tsai DE, Hardy CL, Tomaszewski JE, Kotloff RM, Oloff KM, Somer BG, Schuster SJ, Porter DL, Montone KT, Stadtmauer EA. *Transplantation* 2001 Apr 27;71(8):1076-88

98. Milpied N, Vasseur B, Parquet N et al. *Ann Oncol* 2000;11 Suppl 1:113-6
99. Swinnen LJ et al. *Blood* 1995;86:3333-40
100. Mamzer-Bruneel MF, Lome C, Morelon E et al. *J Clin Oncol* 2000 Nov 1;18(21):3622-32
101. Littler E et al. *EMBO* 1986 J 5, 1959-1966
102. Mentzer SJ et al. *Blood Cell 1998 Molecules and Diseases* 30, 114-123.
103. Öberg B. *Pharmacology & Therapeutics* 1989 2, 213.
104. Oertel S et al. *British J Haematology* 2002, accepted.
105. Coiffier B, Lepage E, Briere J et al. *N Engl J Med* 2002 Jan 24;346(4):235-42
106. Zilz ND, Olson LJ, McGregor CG et al. *J Heart Lung Transplant* 2001 Jul;20(7):770-2
107. Verschuuren EA, Stevens SJ, van Imhoff GW et al. *Transplantation* 2002 Jan 15;73(1):100-4
108. Cook RC, Connors JM, Gascoyne RD et al. *Lancet* 1999 Nov 13;354(9191):1698-9
109. Choquet S, Herbrecht R, Socie G et al. *Annals of oncology* 2002 13 ;supplement 2 :37
110. Oertel SH, Zeidler. K, Grefer J et al. *Blood* 2002 supplement.
111. Knowles DM, Cesarman E, Chadburn A et al. *Blood*. 1995;85:552-565.
112. Cesarman E, Chadburn A, Liu YF et al. *Blood*. 1998;92:2294-2302.
113. H.A. Poirel, A. Schneider, M. Meddeb, *Blood* 2002 supplement.
114. Curtis RE, Travis LB, Rowlings PA et al. *Blood*, 1999 ;94 :2208-2216.



## 12. Appendices

### Addendum A

WHO toxicity-scale					
Toxicity	Grade 0	Grade 1	Grade 2	Grade 3	Grade 4
Hgb g/100ml	≥11,0	9,5-10,9	8,0-9,4	6,5-7,9	<6,5
WBC	≥4,0	3,0-3,9	2,0-2,9	1,0-1,9	<1,0
PLT	≥100	75-99	50-74	25-49	<25
Bilirubin	≤1,25xN	1,26-2,5xN	2,6-5xN	5,1-10xN	>10xN
Transaminase SGOT/SGPT	≤1,25xN	1,26-2,5xN	2,6-5xN	5,1-10xN	>10xN
Alk phos	≤1,25xN	1,26-2,5xN	2,6-5xN	5,1-10xN	>10xN
Creatinine	≤1,25xN	1,26-2,5xN	2,6-5xN	5,1-10xN	>10xN
Bleeding	none	petechial	little blood loss	severe blood loss	life- threatening blood loss
Proteinuria	no change	<3g/l	3-10g/l	>10g/l	nephrotic syndrome
Hematuria	neg	microscopic only	macroscop.	macro and clots	obstructive uropathia
Vomiting/ Nausea	none	Nausea without vomiting	episodes of vomiting	requires antiemetic therapy	uncontrollable vomiting
Lung	no change	mild change	dyspnea at activity	dyspnea at rest	completely bedfast
Stomatitis	none	painless ulcers, mild soreness	painfull ulcers, can eat	painfull ulcers can eat special food	cannot eat
Diarrhea	none	transient, <2days	tolerable, >2days	requires meds	hemoragic, dehydration
Drugfever	none	T<38C	T 38C-40C	T>40C	fever with hypotension
Allergy	none	Edema	mild brochospas m	bronchospas m, requires parenteral meds	anaphylaxis
Dermatology	none	Erythema	dry des- quamation, papular eruption, pruritus	moist desquamation ulceration	exfoliative dermatitis
Alopecia	none	mild	pronounced hair loss	total hair loss, reversible	total hair loss (irreversible)
Infection	none	mild	oral antibiotics	parenteral antibiotics	sepsis
Pain	normal	non- narcotics	oral narcotics	parenteral narcotics	uncontrollable

## Addendum B

### General definition criteria for evaluation of antineoplastic chemotherapy (WHO 1979)

#### Complete remission (CR)

Entire regression of all tumour findings for at least four weeks.

#### Partial remission (PR)

decrease of more than 50 % of the tumour for at least four weeks, no recent metastases, no tumour progression in any location.

#### No change (NC)

Decrease of less than 50 % of the tumour; increase of the tumour of less than 25 % in one or more locations for at least four weeks.

#### Progression (PD)

Increase of more than 25 % of the tumour in one or more locations; new tumour manifestations.

### WHO - Performance - Status

#### Degree                      Performance Status

0	Normal activity
1	Patient is an outpatient, can do light work
2	Patient is an outpatient, cares for himself, work is limited to 50 %
3	caring for himself is limited, bed-bound to 50 %
4	completely dependent on help, bed-bound to 100 %

## Addendum C

### Empfehlungen zur Bewertung des Allgemeinzustands des Patienten

ECOG-Zubrod		Karnofsky	
Grad	Beschreibung	Index%	Beschreibung
<b>0</b>	volle Aktivität, normales Leben möglich	<b>100</b>	Normalzustand, keine Beschwerden, keine manifeste Erkrankung
		<b>90</b>	normale Leistungsfähigkeit, geringe Krankheitssymptome
<b>1</b>	eingeschränkte Aktivität, leichte Arbeit möglich	<b>80</b>	normale Leistungsfähigkeit auch bei Anstrengung, geringe Krankheitssymptome
		<b>70</b>	eingeschränkte Leistungsfähigkeit, arbeitsfähig, selbstversorgend
<b>2</b>	Selbstversorgung möglich, nicht arbeitsfähig, nicht bettlägerig, muß <50% der Tageszeit ruhen	<b>60</b>	eingeschränkte Leistungsfähigkeit, braucht gelegentlich fremde Hilfe
		<b>50</b>	Eingeschränkte Leistungsfähigkeit, braucht krankenschwägerische/ärztliche Betreuung, nicht dauerhaft bettlägerig
<b>3</b>	Selbstversorgung sehr eingeschränkt, >50% der Tageszeit ruhebedürftig, Pflege/Hilfe notwendig	<b>40</b>	Patient ist bettlägerig, braucht spezielle Pflege
		<b>30</b>	Patient ist schwerkrank, Krankenhauspflege ist notwendig
<b>4</b>	bettlägerig und völlig Pflegebedürftig	<b>20</b>	Patient ist schwerkrank, Krankenhauspflege und supportive Therapie erforderlich
		<b>10</b>	Patient ist moribund, Krankheit schreitet rasch fort
		<b>0</b>	Patient ist tot

## **Addendum D**

### **SEPTEMBER 1989 - WORLD MEDICAL ASSOCIATION DECLARATION OF HELSINKI**

Recommendations guiding physicians in biomedical research involving human subjects.

Adopted by the 18th World Medical Assembly - Helsinki, Finland, June 1964 and amended by the 29th World Medical Assembly - Tokyo, Japan, October 1975; 35th World Medical Assembly - Hong Kong, September 1989.

#### **INTRODUCTION**

It is the mission of the physician to safeguard the health of the people. His or her knowledge and conscience are dedicated to the fulfilment of this mission.

The Declaration of Geneva of the World Medical Association binds the physician with the words, „ The health of my patient will be my first consideration,“ and the International Code of Medical Ethics declares that, „ A physician shall act only in the patient's interest when providing medical care which might have the effect of weakening the physical and mental condition of the patient.“

The purpose of biomedical research involving human subjects must be to improve diagnostic, therapeutic and prophylactic procedures and the understanding of the aetiology and pathogenesis of disease.

In current medical practice most diagnostic, therapeutic or prophylactic procedures involve hazards. This applies especially to biomedical research.

Medical progress is based on research which ultimately must rest in part on experimentation involving human subjects.

In the field of biomedical research a fundamental distinction must be recognised between medical research in which the aim is essentially diagnostic or therapeutic for a patient, and medical research, the essential object of which is purely scientific and without implying direct diagnostic or therapeutic value to the person subjected to the research.

Special caution must be exercised in the conduct of research which may affect the environment, and the welfare of animals used for research must be respected.

Because it is essential that the results of laboratory experiments be applied to human beings to further scientific knowledge and to help suffering humanity, the World Medical association has prepared the following recommendations as a guide to every physician in biomedical research involving human subjects. They should be kept under review in the future. It must be stressed that the standards as drafted are only a guide to physicians all over the world.

**Addendum E**

Addendum E



---

 UNIVERSITÄTSKLINIKUM · MEDIZINISCHE FAKULTÄT DER HUMBOLDT-UNIVERSITÄT ZU BERLIN
 

---

Medizinische Klinik mit Schwerpunkt  
Hämatologie und Onkologie  
Professor H. Riess/ Dr. R. Trappe  
Charite-Campus Virchow  
Augustenburger Platz 1  
13344 BERLIN  
Tel.: +49 30-450-553510  
Fax.: +49 30-450-553901

*Berlin, den 13.10.2003*

**Patienteninformation**

**Behandlung von Patienten mit Post-Transplantations Lymphoproliferativer  
Erkrankung (PTLD) mit dem Anti CD-20 Antikörper Rituximab und  
anschließender Chemotherapie nach dem CHOP-Schema mit G-CSF  
Unterstützung**

**Treatment of patients with Post Transplantation Lymphoproliferative Disorders  
(PTLD) with a sequential treatment consisting of anti CD20 antibody rituximab  
and CHOP + G-CSF chemotherapy**

Sehr geehrte Patientin, sehr geehrter Patient,

nachdem bei Ihnen eine Organtransplantation des Herzens, der Lunge, der Leber, der Niere, ..... (unzutreffendes bitte streichen) oder in Kombination durchgeführt wurde, leiden Sie jetzt an einer Lymphzellerkrankung. Die genaue Bezeichnung ist: Post-Transplantations Lymphoproliferative Erkrankung (PTLD).

Wir bitten Sie um Ihr Einverständnis zur Teilnahme an einer wissenschaftlichen Untersuchung zur Behandlung Ihrer Erkrankung. Das im folgenden beschriebene Medikament wird zur Behandlung in der klinischen Medizin regelmäßig bei Ihrer und ähnlichen Erkrankungen eingesetzt. Über die jeweiligen Risiken und unerwünschten Nebenwirkungen werden Sie gesondert, weitergehend aufgeklärt und um Ihr Einverständnis gebeten.

Sie sollen ein gegen das lymphatische System gerichtetes Medikament mit dem Namen Rituximab erhalten. Rituximab ist ein Medikament, welches zur Gruppe der sogenannten monoklonalen Antikörper gehört. Diese Medikamente binden sich an Strukturen auf der Oberfläche von bösartigen Zellen. Die Struktur, die sich auf den

Zellen von PTLDs finden läßt, heißt CD20 Antigen und Rituximab ist gegen diese Struktur gerichtet. Rituximab bindet an diese Struktur und vermittelt dadurch die Zerstörung dieser Zellen. Rituximab wird über eine Vene appliziert. Die Nebenwirkungen einer Therapie mit Rituximab sind gut bekannt. Da es sich bei diesem Medikament um ein Protein handelt, sind allergische Reaktionen wie Fieber, Schüttelfrost, Übelkeit, Erbrechen, Erytheme, Mangel an Blutplättchen und an roten und weißen Blutzellen und Bauchschmerzen bis hin zum anaphylaktischen Schock nicht auszuschließen. Um diese möglichen allergischen Reaktionen zu vermeiden, werden Sie mit einer antiallergischen Therapie vorbehandelt werden.

Nach einer Therapiepause von 4 Wochen werden Sie mit einer bei Lymphzellerkrankungen erprobten Zytostatika-Kombination behandelt. Es handelt sich um eine Kombination der Zellgifte Cyclophosphamid, Vincristin, Adriamycin zusammen mit dem Hormonpräparat Prednisolon. Diese Zytostatika haben die für alle derartigen Medikamente typischen Nebenwirkungen, insbesondere eine vorübergehende hemmende Wirkung auf das Knochenmark, bei zu hoher Dosierung eine Beeinträchtigung des Herzmuskels und Störung der Nervenfunktionen; sie können zu vorübergehender Übelkeit und zu vorübergehenden Haarverlust führen. Um die Nebenwirkungen auf das blutbildende Knochenmark so kurz und so mild wie möglich zu halten, werden Sie im Anschluss an die Chemotherapie mit einem Medikament (G-CSF) behandelt. Eine 3- bis 5- monatige Behandlung mit diesen Zytostatika führt bei der Mehrzahl der Patienten zu einer vorübergehenden oder dauerhaften Rückbildung der PTLD.

Während der gesamten Behandlungsdauer unterliegen Sie einer sorgfältigen medizinischen Überwachung. Es ist damit vorgesorgt, daß in dieser Zeit kein unerwünschter Krankheitsverlauf unbemerkt bleibt, und daß eventuelle unerwünschte Nebenwirkungen berücksichtigt und behandelt werden.

#### *Aufklärung über den Datenschutz*

*Sofern und soweit Sie darin einwilligen, werden Ihre im Rahmen der o.g. Studie von der Studienärztin/vom Studienarzt erhobenen Daten wie folgt verarbeitet:*

*Ihr Name, Geschlecht, Geburtsdatum werden auf der Einwilligungserklärung vermerkt und elektronisch aufgezeichnet. Diese Angaben bleiben bei der Studienärztin/bei dem Studienarzt.*

Die im Rahmen der o.g. Studie erhobenen Angaben über Ihre Gesundheit bzw. Krankheit, werden von der Studienärztin/dem Studienarzt getrennt von Ihren persönlichen Angaben handschriftlich und/oder elektronisch aufgezeichnet und mit einer Kennziffer versehen, die nur der/dem Studienärztin/ Studienarzt eine Zuordnung der Krankheits- bzw. Gesundheitsdaten zu Ihrer Person ermöglicht. Soweit jedoch die im Rahmen der o.g. Studie ermittelten Daten für die Diagnose Ihrer Erkrankung bzw. Ihre weitere Behandlung wichtig sind, werden diese auch in Ihre Krankenakte aufgenommen.

Die nach Gruppen zusammengestellten Ergebnisse der o.g. Studie werden ohne Bezugsmöglichkeit auf Ihre Person voraussichtlich in einer medizinischen Fachzeitschrift veröffentlicht.

**Dem Sponsor dieser Studie, der Firma Hoffmann-La Roche AG, Emil-Barell-Str. 1, D-79639 Grenzach-Wyhlen, sowie den zuständigen in- und ausländischen Überwachungsbehörden und Bundesoberbehörde können die im Rahmen der o.g. Studie aufgezeichneten verschlüsselten Angaben über Ihre Gesundheit bzw. Krankheit zum Zweck der o.g. Studie weitergegeben bzw. elektronisch übermittelt werden.**

**Ferner erhalten zur Verschwiegenheit verpflichtete Vertreter der vorgenannten Stellen in Einzelfällen Einblick in die Ihre Teilnahme an der o.g. Studie betreffenden Aufzeichnungen beim Prüfarzt, aus denen auch Ihr Name, Ihre Adresse sowie Ihr vollständiges Geburtsdatum hervorgeht. Hierdurch soll insbesondere sichergestellt werden, dass die vom Prüfarzt übermittelten Angaben richtig sind.**

Die außerhalb Ihrer Krankenakte aufgezeichneten Daten werden bis zum Ablauf der Zulassung der Prüfsubstanz, die in die Krankenakte aufgenommenen Daten 30 Jahre aufbewahrt und danach gelöscht bzw. vernichtet.

Sie haben das Recht, Auskunft über die Sie betreffenden aufgezeichneten Angaben und Ergebnisse Ihrer Untersuchung bzw. Behandlung zu verlangen, soweit dies aus technischen Gründen noch möglich ist. Sie können bei unrichtiger Aufzeichnung von Angaben, die Ihre Person betreffen, auch eine Berichtigung dieser Angaben verlangen.

Sollten Sie einer Weiterverarbeitung Ihrer Daten widersprechen, werden keine weiteren Daten über Ihre Person zum Zweck der o.g. Studie erhoben und aufgezeichnet. Die bis zu diesem Zeitpunkt vorhandenen Daten müssen aber

*möglicherweise aus Gründen der Sicherheit anderer Studien-teilnehmer/-innen und der Wahrung gesetzlicher Dokumentationspflichten weiter verarbeitet werden. Gleiches gilt für eine von Ihnen verlangte Löschung der Sie betreffenden Angaben.*

### *Freiwilligkeit der Teilnahme*

Die Entscheidung zur Teilnahme an dieser Untersuchung ist freiwillig. Sollten Sie nicht teilnehmen wollen, so ändert sich nichts an Ihrem zukünftigen Verhältnis zu dem behandelnden Arzt. Es steht Ihnen auch jederzeit frei, Ihre Zustimmung zu widerrufen und eine weitere Teilnahme an der Studie abzulehnen.

### Versicherungsschutz

Für den Fall, dass Sie als Folge der Teilnahme an dieser Behandlungsstudie irgendeinen Schaden erleiden sollten, wurde für Sie eine Patientenversicherung bei der „AXA Versicherung AG, Colonia-Allee 10-20, 51067 Köln“ unter der Policen Nr 60226010434 abgeschlossen. Zur Wahrung des Versicherungsschutzes ist es allerdings erforderlich:

- eine andere medizinische Behandlung während der Dauer der Prüfung nur mit Zustimmung des Prüfarztes aufzunehmen (dies gilt selbstverständlich nicht für Notfälle; in diesem Fall ist der Prüfarzt aber zu informieren).
- einen möglichen Schaden unverzüglich dem Prüfarzt und der Versicherung zu melden und alle zweckmäßigen Maßnahmen zur Aufklärung der Ursache und des Umfangs und zur Minderung des Schadens zu unterstützen.
- ihre behandelnden Ärzte, Kranken- oder Sozialversicherer auf verlangen des Patientenversicherers zu beauftragen, Bericht über den Gesundheitsschaden zu erstellen und diese auch zur Auskunftserteilung zu ermächtigen.



**Weitere Fragen**

Wenn Sie weitere Fragen haben, so wenden Sie sich bitte an Ihren behandelnden Arzt

**Frau/Herr Dr.:** \_\_\_\_\_

**Telefonnummer:** \_\_\_\_\_

Er/Sie wird Ihre Fragen jederzeit gern beantworten.

Folgende Punkte wurden zusätzlich besprochen:

---

---

---

---

---

Medizinische Klinik mit Schwerpunkt  
Hämatologie und Onkologie  
Professor H. Riess/ Dr. R. Trappe  
Charite-Campus Virchow  
Augustenburger Platz 1  
13344 BERLIN  
Tel.: +49 30-450-553510  
Fax.: +49 30-450-553901

*Berlin, den 13.10.2003*

**Einwilligungserklärung**

**Behandlung von Patienten mit Post-Transplantations Lymphoproliferativer  
Erkrankung (PTLD) mit dem Anti CD-20 Antikörper Rituximab und  
anschließender Chemotherapie nach dem CHOP-Schema mit G-CSF  
Unterstützung**

**Treatment of patients with Post Transplantation Lymphoproliferativ Disorders  
(PTLD) with a sequential treatment consisting of anti CD20 antibody rituximab  
and CHOP + G-CSF chemotherapy**

*Hiermit erkläre ich,*

**Vorname:** \_\_\_\_\_

**Name:** \_\_\_\_\_

**Adresse:** \_\_\_\_\_

**Geburtsdatum:** \_\_\_\_\_

**PatientenNr:** \_\_\_\_\_

*dass ich durch*

**Herrn/Frau Dr.** \_\_\_\_\_

**Adresse:** \_\_\_\_\_

*mündlich und schriftlich über das Wesen, die Bedeutung, Tragweite und Risiken der wissenschaftlichen Untersuchung im Rahmen der o.g. Studie, die von der Charité-Klinik f. Hämatologie/Onkologie Campus Virchow-Klinikum durchgeführt wird, informiert wurde und ausreichend Gelegenheit hatte, meine Fragen hierzu in einem Gespräch mit dem/der Prüfarzt/in zu klären.*

*Ich habe insbesondere die mir vorgelegte Patienteninformation vom  
Datum: \_\_\_\_\_ verstanden und eine Ausfertigung derselben und dieser  
Einwilligungserklärung erhalten.*

*Ich bin bereit, an der wissenschaftlichen Untersuchung im Rahmen der o.g. Studie teilzunehmen.*

*Mir ist bekannt, dass ich meine Einwilligung jederzeit ohne Angabe von Gründen und ohne nachteilige Folgen für mich zurückziehen und einer Weiterverarbeitung meiner Daten jederzeit widersprechen kann.*

*Ich wurde über den bestehenden Versicherungsschutz und die damit für mich verbundenen Verpflichtungen informiert.*

*Ich bin damit einverstanden, dass der Prüfleiter oder -arzt sich mit meinem/r behandelndem/n Arzt/Ärztin im Rahmen dieser Studie in Verbindung setzt.*

## **Einwilligungserklärung zur Datenverarbeitung**

***Ich willige darin ein, dass die wissenschaftliche Einrichtung: Medizinische Klinik mit Schwerpunkt Hämatologie und Onkologie, Charite-Campus Virchow, Augustenburger Platz 1, 13344 BERLIN mich betreffende personenbezogene Daten und Gesundheits- bzw. Krankheitsdaten im Rahmen und zum Zweck des o.g. Forschungsvorhabens verarbeitet.***

***Ich willige darin ein, dass meine im Rahmen der o.g. Studie erhobenen Krankheitsdaten aufgezeichnet, verschlüsselt, verschlüsselt gespeichert und an den Sponsor Hoffmann-La Roche AG, Emil-Barell-Str. 1, D-79639 Grenzach-Wyhlen, sowie an die zuständigen Überwachungsbehörden und die zuständige Bundesoberbehörde weitergeleitet und anonymisiert veröffentlicht werden.***

***Ferner bin ich damit einverstanden, dass einem/er zur Verschwiegenheit verpflichteten Beauftragten des Sponsors Hoffmann-La Roche AG, Emil-Barell-Str. 1, D-79639 Grenzach-Wyhlen sowie der zuständigen Überwachungsbehörde und Bundesoberbehörde zu Prüfzwecken stichprobenartig Einsicht in die im Rahmen der o.g. Studie aufgezeichneten Krankheitsdaten, soweit es sich um personenbezogenen Daten handelt, gewährt wird.***

***Ich erkläre mich auch mit einer Information meines Hausarztes durch den/die Studienarzt/Studienärztin über meine Teilnahme an der o.g. Studie einverstanden.***

*Im Rahmen der vorstehend beschriebenen Weitergabe von Daten und Einsichtnähmegewährung in die mich betreffenden Aufzeichnungen entbinde ich hiermit den/die behandelnden Arzt/Ärztin und den/die Studienarzt/Studienärztin von seiner/ihrer ärztlichen Schweigepflicht.*

\_\_\_\_\_ Datum

\_\_\_\_\_ Unterschrift des / der Versicherungsteilnehmer/in

*Hiermit erkläre ich, den/die o.g. Versuchsteilnehmer/in am \_\_\_\_\_ über Wesen, Bedeutung, Tragweite und Risiken der o.g. Studie mündlich und schriftlich aufgeklärt und ihm/ihr eine Ausfertigung der Information sowie dieser Einwilligungserklärung übergeben zu haben.*

\_\_\_\_\_ Datum

\_\_\_\_\_ Unterschrift des / der aufklärenden Prüfarztes/-ärztin

**Addendum F**

Sending institution

Institute of Pathology  
PD Dr. I. Anagnostopoulos  
Universitätsklinikum Benjamin Franklin  
Hindenburgdamm 30  
12200 Berlin

**Post-Transplantation lymphoproliferative disorders**

H.No.:

Date of

acceptance:

**Data of patient**

Name, Christian Name:

Maiden Name:

Sex: male/ female:

Date of birth:

Address:

Transplanted organ:

**Current excision**

Kind of sample:

Localisation:

**Addendum F**

Sending institution

Institute of Pathology  
Prof Bettina Borisch  
Hopitaux Universitaires de Geneve  
1, Rue Michel Servet  
CH-1211 Genève 14

**Post-Transplantation lymphoproliferative disorders**

H.No.:

Date of

acceptance:

**Data of patient**

Name, Christian Name:

Maiden Name:

Sex: male/ female:

Date of birth:

Adress:

Transplanted organ:

**Current excision**

Kind of sample:

Localisation:

**Addendum F**

Sending institution

Institute of Pathology  
Dr. Martine Raphael  
Hôpital Avicenne  
125 route de Stalingrad  
F-93009 Bobigny cedex

**Post-Transplantation lymphoproliferative disorders**

H.No.:

Date of

acceptance:

**Data of patient**

Name, Christian Name:  
Maiden Name:  
Sex: male/ female:  
Date of birth:  
Adress:  
Transplanted organ:

**Current excision**

Kind of sample:

Localisation:

**Addendum G****Adresse:**

Universität Homburg/Saar  
Abteilung Virologie  
Kirrbergerstr. Haus 47  
D-66421 Homburg/Saar

<b>EBV-PCR</b>
----------------

Phone ++49-6841-1623932 Fax: ++49-6841-1623980 e-mail: vibgae@uniklinik-saarland.de

**Patienten Identifikation :**

Name: \_\_\_\_\_

Geburtsdatum: \_\_\_\_\_

**Proben Identifikation:**

Material (am besten sind 2 ml EDTA Vollblut)

? EDTA Vollblut ? Serum ? Liquor ? Biopsie \_\_\_\_\_ ? andere \_\_\_\_\_

Datum: \_\_\_\_\_

**Klinische Daten:**

Transplantation ? SCT ? Niere ? Lunge ? Herz ? Leber ? Pankreas ? andere \_\_\_\_\_

Datum der Transplantation: \_\_\_\_\_

EBV Status vor Transplantation (EBV-VCA-IgG):

Empfänger: ? positiv ? negativ

Spender: ? positiv ? negativ

**Einsender:**

Name des betreffend Arztes: \_\_\_\_\_

Adresse:

Fax: \_\_\_\_\_

Tel: \_\_\_\_\_

**Verpackung und Transport:**

Proben müssen in einem verschließbaren Plastikröhrchen abgenommen werden, das mit der Patienten Identifikation beschriftet ist. Das Probenröhrchen muss in einem Plastik-Sicherheitstransportgefäß verschickt werden. Es sollte möglichst sofort verschickt werden, eine Kühlung während des Transportes ist nicht notwendig. (Wenn eine Lagerung unumgänglich ist, sollte die Proben bei +4 °C aufbewahrt werden).